

IPG100 Internet Protocol Gateway

User's Manual

Revision 1.1

Copyright © 2011 Maretron, LLP All Rights Reserved

Maretron, LLP
9014 N. 23rd Ave #10
Phoenix, AZ 85021
<http://www.maretron.com>

Maretron Manual Part #: M003004

Revision History

Revision	Description
1.0	Original document
1.1	Corrected current utilization figures

Table of Contents

1	General	1
1.1	Introduction	1
1.2	Firmware Revision	2
1.3	Features	2
1.4	IPG100 Accessories	2
1.5	Quick Install	2
1.6	Theory of Operation	2
1.7	General Concepts	3
1.7.1	Client/Server Architecture	3
1.7.2	TCP/IP Networks	5
1.7.3	NAT (Network Address Translation)	5
1.7.4	PAT (Port Address Translation)	6
1.7.5	Static and Dynamic IP Addressing	6
1.7.6	Software Firewall Configuration	7
1.7.7	Data Security and Encryption	7
2	Installation	7
2.1	Unpacking the Box	7
2.2	Choosing a Mounting Location	8
2.3	Mounting the IPG100	8
2.4	Connecting the IPG100	9
2.4.1	NMEA 2000® Connection	9
2.4.2	LAN Connection	9
2.4.3	USB N2KView® Hardware License Key Connection	9
2.5	Indicators	10
3	Configuring the IPG100	10
3.1	Advanced Configuration	10
3.1.1	Device Instance	10
3.1.2	Installation Description	11
3.1.3	Restore Factory Defaults	11
3.2	Device Label	11
3.3	N2KServer® Password	11
3.4	Configuring DHCP	11
3.5	Configuring IP Address	11
3.6	Configuring Subnet Mask	11
3.7	Configuring Default Gateway	12
3.8	Configuring Default DNS	12
4	Maintenance	12
5	Troubleshooting	13
6	Technical Specifications	14
7	Technical Support	16
8	Installation Template	17
9	Maretron (2 Year) Limited Warranty	18

Table of Figures

Figure 1 – IPG100 Network Diagram.....	1
Figure 2 – LAN Client/Server Architecture Example with USB100	3
Figure 3 – WAN Client/Server Architecture Example through the Internet	4
Figure 4 – LAN Server/Client Architecture Example with IPG100	4
Figure 5 – Single Client Connection to IPG100	5
Figure 6 – Mounting the IPG100.....	8
Figure 7 – NMEA 2000® Connector Face Views	9
Figure 8 – Troubleshooting Guide	13
Figure 9 – Mounting Surface Template	17

1 General

1.1 Introduction

Congratulations on your purchase of the Maretron Internet Protocol Gateway (IPG100). Maretron has designed and built your gateway to the highest standards for years of reliable, dependable, and accurate service.

The Internet Protocol Gateway (IPG100) lets you connect Maretron black boxes (MBB100's), Maretron touch screens (DSM800's), PC's, Mac's, tablets, or smartphones to an NMEA 2000® network so you can monitor and control your vessel using Maretron's N2KView® software. The conventional way of viewing NMEA 2000® information is with a display on the vessel that is directly connected to an NMEA 2000® network, but with the IPG100, you are not limited to direct connected displays. With the IPG100, you can use any device running N2KView® software to monitor and control your vessel from onboard or ashore.

The IPG100 has an NMEA 2000® and an Ethernet LAN (Local Area Network) port for exchanging information between the onboard NMEA 2000® network and Internet Protocol (IP) enabled devices using conventional technology such as routers, switches, and wireless modems. In addition, the IPG100 includes a USB port used for connecting Maretron's hardware license key. The hardware license key is used to enable remote devices running N2KView® software. For example, if you purchase a hardware license key with three N2KView® licenses, you can run N2KView® at the helm, another on a handheld device connected via Wi-Fi, and another at home on your PC or Mac with an Internet connection back to the vessel. The licenses are floating, so if you were to shut down N2KView® running at home, you could fire up the third N2KView® license on the vessel.

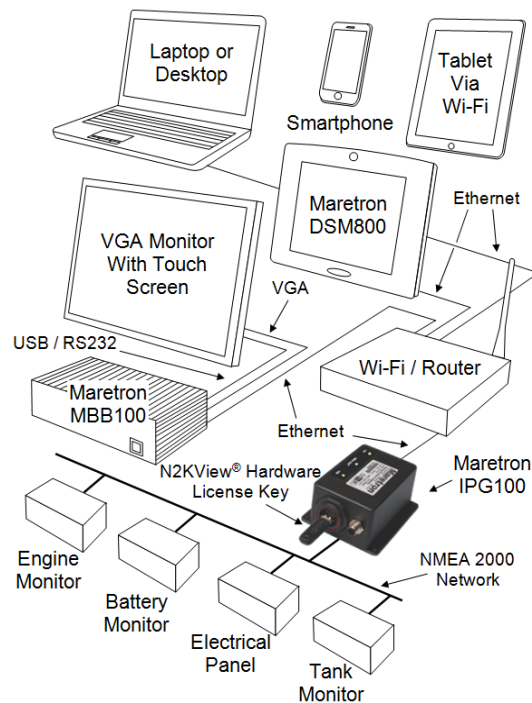

Figure 1 – IPG100 Network Diagram

The Maretron IPG100 is designed to operate within the harsh demands of the marine environment. However, no piece of marine electronic equipment can function properly unless installed, calibrated, and maintained in the correct manner. Please read carefully and follow these instructions for installation, calibration, and usage of the Maretron IPG100 in order to ensure optimal performance.

1.2 Firmware Revision

This manual corresponds to IPG100 firmware revision 1.0.0.

1.3 Features

The Maretron IPG100 has the following features:

- NMEA 2000[®] interface
- 10/100 Mbps Ethernet LAN interface
- Runs embedded version of Maretron N2KServer[®] software
- USB port for N2KView[®] Hardware License Key
- Dedicated platform for N2KView[®] clients

1.4 IPG100 Accessories

Maretron offers the following accessories for the IPG100:

- PX0852 USB Waterproof Cover
- PX0837/5M00 Waterproof Ethernet Cable 16.4'

1.5 Quick Install

Installing the Maretron IPG100 involves the following steps. Please refer to the individual sections for additional details.

1. Unpacking the Box (Section 2.1)
2. Choosing a Mounting Location (Section 2.2)
3. Mounting the IPG100 (Section 2.3)
4. Connecting the IPG100 (Section 2.4)
5. Configuring the IPG100 (Section 3)

1.6 Theory of Operation

The IPG100 implements the server portion of the N2KView[®] Vessel Monitoring and control System, providing the same function as the N2KServer[®] component running on a Windows PC. The IPG100, when connected to an NMEA 2000[®] network, an Ethernet LAN, and a valid N2KView[®] Hardware License Key, takes the information from the NMEA 2000[®] network and makes it available to N2KView[®] clients over the LAN interface. N2KView[®] platinum clients can also send switching control messages to the IPG100 over the LAN interface and the IPG100 will relay these messages to the NMEA 2000[®] network. The next section describes in detail how the N2KView[®] system is implemented in terms of networking technology.

1.7 General Concepts

1.7.1 Client/Server Architecture

The N2KView® Vessel Monitoring and Control System is based on a client/server architecture. In this context, a *server* is defined as a component that provides services over a network and a *client* is defined as a station that requests and uses those services.

Within the N2KView® System, there is one server (called N2KServer®) and one or more stations or clients (called N2KView®). The server component is implemented by either an IPG100 or N2KServer® software running on a Windows PC, and the station or client components are implemented by the N2KView® software. N2KView® software may run on a Windows PC, Mac, or Maretron's MBB100 or DSM800. Mobile versions of N2KView® software are available for iPod, iPhone, iPad and Android devices. The service offered by the server to the stations (*clients*) is access to the NMEA 2000® network data that the server receives from the NMEA 2000® network via its NMEA 2000® gateway. The network over which this service is offered is implemented as a TCP/IP (Transmission Control Protocol/Internet Protocol) network, which is discussed in the next section.

1.7.1.1 Examples of NMEA 2000® Client/Server Architectures

N2KServer® may run on a Windows PC (using Maretron's USB100 gateway - see Figure 2 and Figure 3) or N2KServer® may run directly on an IPG100 (see Figure 4).

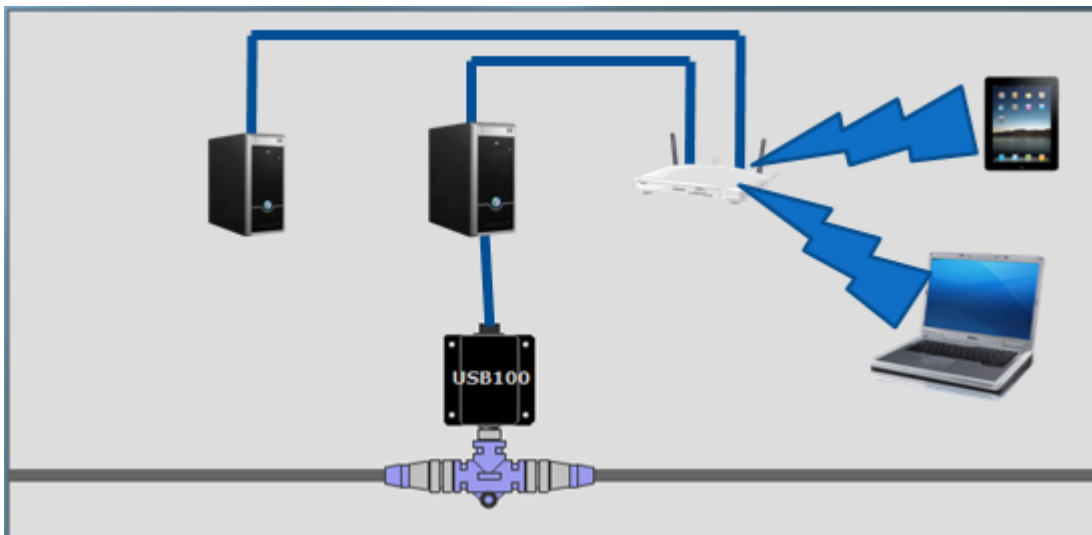

Figure 2 – LAN Client/Server Architecture Example with USB100

Figure 2 shows an example of a Local Area Network (LAN) connection including the PC to NMEA 2000® network connection through a USB100 gateway. A copy of N2KServer® must run on the PC connected to the USB100, and an N2KView® Hardware License Key must be plugged in to the PC to supply sufficient licenses for the maximum number of simultaneously connected clients. N2KView® clients may run on either the PC connected to the USB100, or to another PC connected to the router, or to a laptop or mobile device connected wirelessly.

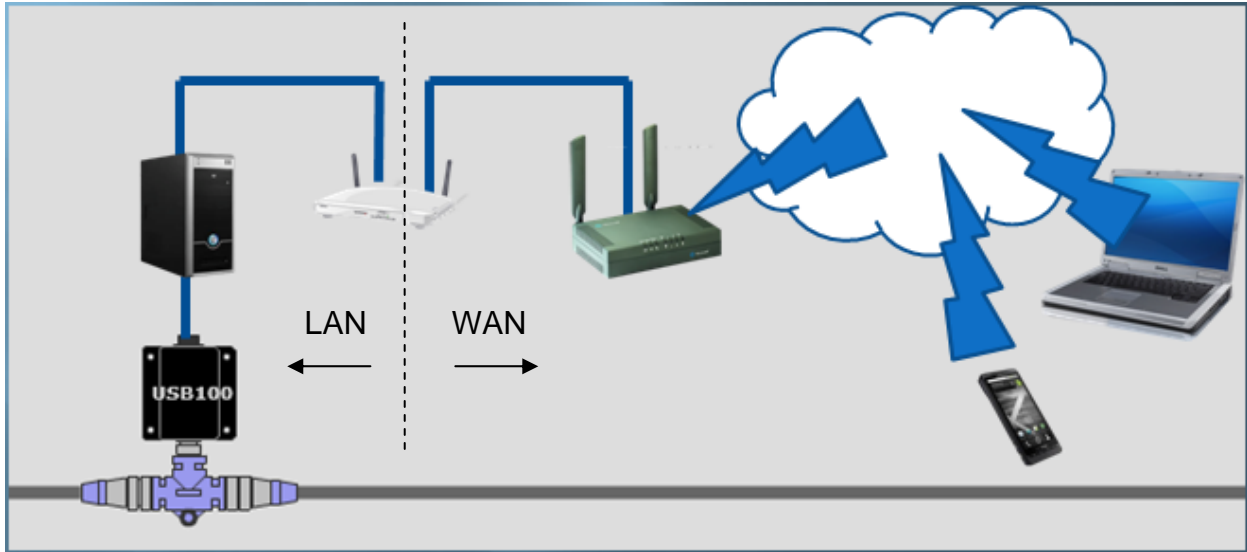

Figure 3 – WAN Client/Server Architecture Example through the Internet

Figure 3 extends the example shown in Figure 2 by adding an external internet access point across a Wide Area Network (WAN). Although it is possible to setup the network as shown in Figure 3, ensuring that the remote N2KView[®] clients can find the IP Address of the N2KServer[®] at the correct port (6543 or 6544) requires considerable IT expertise.

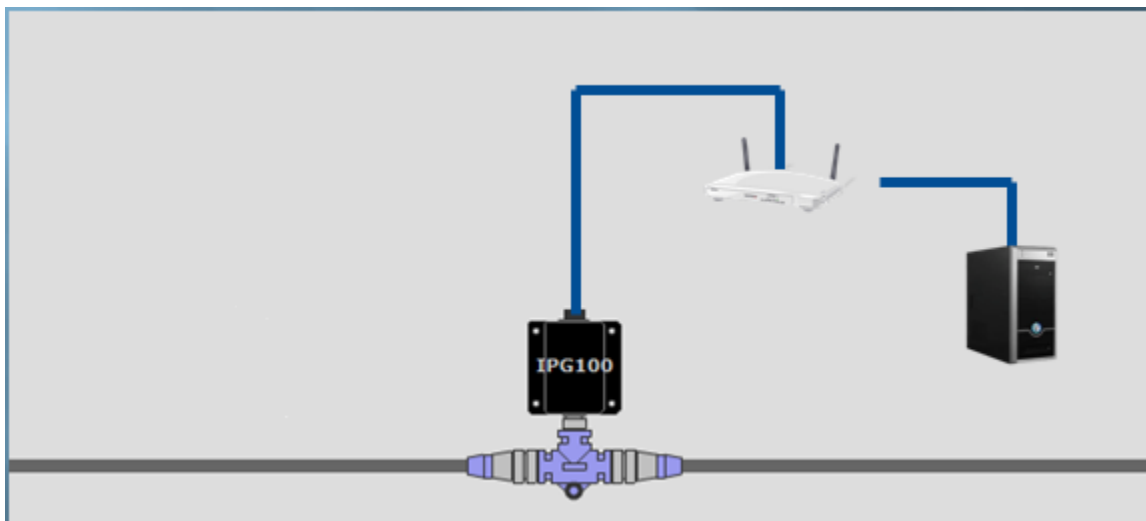

Figure 4 – LAN Client/Server Architecture Example with IPG100

Figure 4 shows an example of an IPG100 connected between the NMEA 2000[®] network and a Wi-Fi/router connected to a PC running an N2KView[®] client. A copy of N2KServer[®] automatically runs on the IPG100; however an N2KView[®] Hardware License Key must be plugged in to the IPG100 to supply sufficient licenses for the maximum number of simultaneously connected clients. As in the previous examples, N2KView[®] Clients may run on any computer able to access the N2KServer[®] on the Ethernet network.

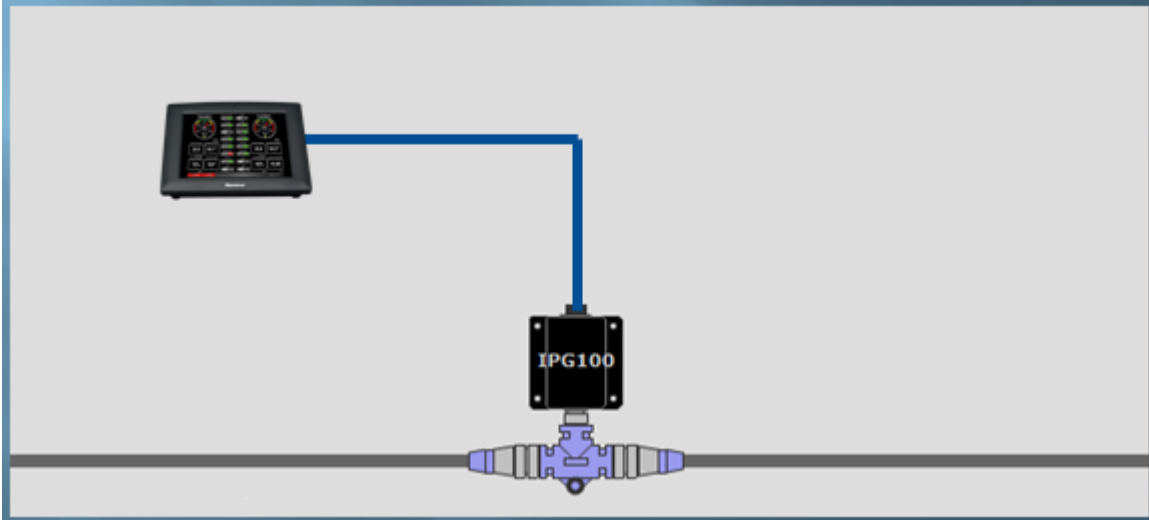

Figure 5 – Single Client Connection to IPG100

Figure 5 shows an example of a single client connection to an IPG100. A DSM800 (or a computer, or a MBB100) is connected directly to the IPG100.

1.7.2 TCP/IP Networks

The networking protocol that is used for the communication between the server and stations in the N2KView® system is the TCP/IP protocol. This protocol is used by the World Wide Web, FTP (File Transfer Protocol), and many others of the most popular applications on the Internet. The TCP/IP connection can be made over an Ethernet connection, a Wi-Fi connection, cellular phone data connection, and many other types of media. In fact, a single packet of TCP/IP data may traverse multiple types of media on its journey. The TCP/IP protocol is supported by most operating systems, as well as Internet-connected cellular phones.

Each computer on a TCP/IP network is identified by an IP address unique to that network. An IP address consists of four numbers, each ranging between 0 and 255, separated by periods. This is referred to a dotted decimal notation. Examples of IP addresses in this format are 10.0.0.1, and 62.12.31.188.

The IP address may either be hard coded into the computer (this means that the address is static which makes the computer easier to find) or assigned at each startup by a DHCP (Dynamic Host Control Protocol) server, typically found as part of a router. The router can be configured to reserve a specific address for the computer and then assign that same address each time at startup. If the router chooses a different address each time, then the computer may be difficult to find on the network. This is not a problem for a client such as N2KView®, but servers such as a PC running N2KServer® or the IPG100 must be at a known address.

1.7.3 NAT (Network Address Translation)

If you wish to use N2KView® to view data from an N2KServer® on a WAN through an Internet connection, please read this section. If your N2KServer® and N2KView® computers are on the same LAN, you may skip this section.

In the early days of the Internet, each computer connected to the Internet had its own *IP address*. With the explosive growth of the Internet, the number of distinct IP addresses is starting to run out. It is no longer practical for an Internet Service Provider (ISP) to provide its customers with individual IP addresses for each component the customer wishes to connect to the Internet. Rather, the ISP normally assigns each customer a single IP address, and a router implementing Network Address Translation (NAT) is connected to the Internet connection (sometimes referred to as the Wide Area Network, or WAN, connection) on one side, and to the Local Area Network, or LAN, on the other side. Each computer on the LAN side of the connection will be assigned its own IP address, typically in the ranges 192.168.x.x, 10.x.x.x, and 172.16.x.x through 172.31.x.x, where x can be any number in the range 0-255. The WAN connection will be assigned a single IP address by the ISP.

Generally, network address translation is performed by a router that is connected to the Internet via a Cable or DSL connection on the WAN side, and to the local area network (LAN) via Ethernet or Wi-Fi connections. In order to access an N2KServer[®] on the local area network from an N2KView[®] outside of the LAN. You must configure the router to allow incoming connections on port 6544 and to forward these connections to the IP address of the N2KServer[®] computer. Consult the documentation that came with your router for details.

1.7.4 PAT (Port Address Translation)

If you wish to use N2KView[®] to view data from an N2KServer[®] on a WAN through an Internet connection and your Internet Service Provider does not allow communication on port 6544, please read this section. If your N2KServer[®] and N2KView[®] computers are on the same LAN, or your ISP allows communication over port 6544, you may skip this section.

N2KServer[®] requires a connection to be made on port 6544. Routers that support Port Address Translation can be set up to accept incoming connections on a different port and to forward these connections to port 6544 on the IP address of the N2KServer[®] computer. This change in the port address is known as the ability to do Port Address Translation as well as Network Address Translation. Not all routers have this ability; please consult the documentation that came with your router for details.

N2KView[®] must then be set up to request a connection to the WAN IP Address of the router and the new port number.

1.7.5 Static and Dynamic IP Addressing

If you wish to use N2KView[®] to view data from an N2KServer[®] on a WAN through an Internet connection, please read this section. If your N2KServer[®] and N2KView[®] computers are on the same LAN, you may skip this section.

If you request a *Static IP Address* from your ISP when you set up your Internet connection, the WAN IP address will always be the same. If you didn't make this request, your ISP will assign you a *Dynamic IP Address*, which may actually change from time to time. In this way, the ISP only needs to have enough addresses to cover its customers who are connected to the Internet at any given time. If you stop or lose your Internet connection, your Dynamic IP address will be released and may be reassigned to someone else.

If you wish to connect to an N2KServer® from outside your vessel's LAN via an Internet connection, you have two choices. First, you can request a static IP address from the ISP for your vessel; secondly, you may register your N2KServer®'s IP address with a "dynamic DNS service", such as the ones offered freely by www.dyndns.org, among others. Please visit their websites for more information on how dynamic DNS services operate.

1.7.6 Software Firewall Configuration

If you wish to run N2KView® and N2KServer® on two separate computers and are running a software firewall product other than Windows Firewall, please read this section. Otherwise, you may skip this section.

A firewall is designed to protect your computer from unfettered access from the Internet. There are two kinds of firewalls: software and hardware. A software firewall is a component such as Windows Firewall or Norton Internet Security. A major function of these programs is to allow your computer to initiate connections out onto the Internet, but to block your computer from receiving incoming connections from the Internet. If you wish to be able to view your vessel's data from another computer, your N2KServer® computer's software firewall must be configured to allow incoming connections from N2KView® stations. The N2KServer® makes these adjustments to the Windows Firewall software when it is installed. If you are running firewall software from another vendor, you may have to configure your firewall software to allow this incoming TCP protocol connection on port 6544.

1.7.7 Data Security and Encryption

Making your vessel's data available over a LAN or WAN presents multiple security concerns. First, it is desirable to keep anyone from viewing your vessel's data without authorization. Second, and more important, it is imperative that no unauthorized persons be able to place data onto your vessel's NMEA 2000® network.

The N2KView® system protects your vessel's data with multiple levels of protection.

First, any data that passes between the N2KServer® server component and any N2KView® station components is protected using industry-standard SSL encryption. This encryption standard is widely used to protect financial information on the internet. Each communication session negotiates a random encryption key every time a connection is established. This makes the data secure over public and private Wi-Fi networks, as well as the internet.

Second, each N2KView® station that wishes to connect to an N2KServer® server component must authenticate itself by means of a *server password*. The server password is transmitted by the N2KView® station to the N2KServer® server over the encrypted communication link. The N2KServer® compares the server password to the one it was programmed with. Only if the server password received from the station matches the server's stored password is the station granted access to the NMEA 2000® network data.

2 Installation

2.1 Unpacking the Box

When unpacking the box containing the Maretron IPG100, you should find the following items:

- 1 – IPG100 Internet Protocol Gateway
- 1 – Parts Bag containing 4 Stainless Steel Mounting Screws
- 1 – IPG100 User's Manual
- 1 – Warranty Registration Card

If any of these items are missing or damaged, please contact Maretron.

2.2 Choosing a Mounting Location

Please consider the following when choosing a mounting location.

1. The IPG100 is waterproof, so it can be mounted in a damp or dry location. Note that the USB Waterproof Cover and Waterproof Ethernet Cable accessories must be purchased to waterproof all of the connections to the IPG100. The NMEA 2000[®] network interface is already waterproof.
2. The orientation is not important, so the IPG100 can be mounted on a horizontal deck, vertical bulkhead, or upside down if desired.
3. The IPG100 is temperature-rated to 55°C (130°F), so it should be mounted away from engines or engine rooms where the operating temperature exceeds the specified limit.

2.3 Mounting the IPG100

Attach the IPG100 securely to the vessel using the included stainless steel mounting screws or other fasteners as shown in Figure 6 below. Do not use threadlocking compounds containing methacrylate ester, such as Loctite Red (271), as they will cause stress cracking of the plastic enclosure.

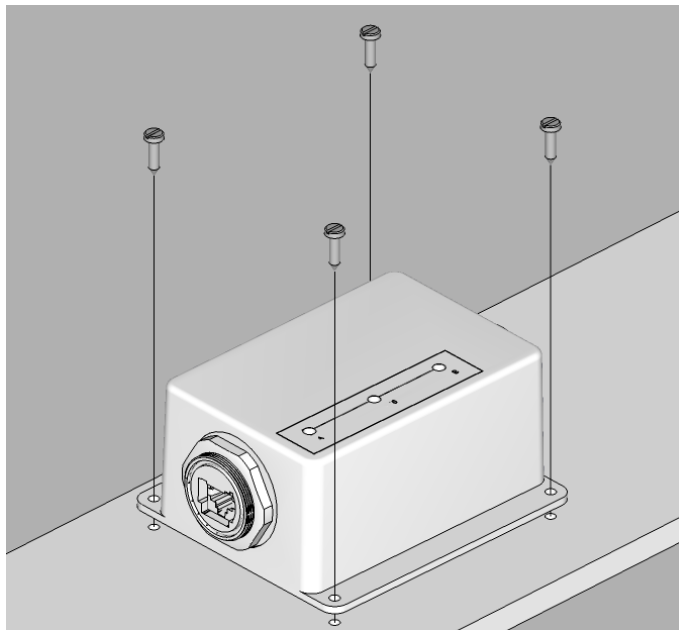

Figure 6 – Mounting the IPG100

2.4 Connecting the IPG100

2.4.1 NMEA 2000® Connection

The NMEA 2000® connector can be found on the side of the enclosure. The NMEA 2000® connector is a round five pin male connector (see Figure 7). You connect the IPG100 to an NMEA 2000® network using a Maretron NMEA 2000® cable (or an NMEA 2000® compatible cable) by connecting the female end of the cable to the IPG100 (note the key on the male connector and keyway on the female connector). Be sure the cable is connected securely and that the collar on the cable connector is tightened firmly. Connect the other end of the cable (male) to the NMEA 2000® network in the same manner. The IPG100 is designed such that you can plug or unplug it from an NMEA 2000® network while the power to the network is connected or disconnected. Please follow recommended practices for installing NMEA 2000® network products.

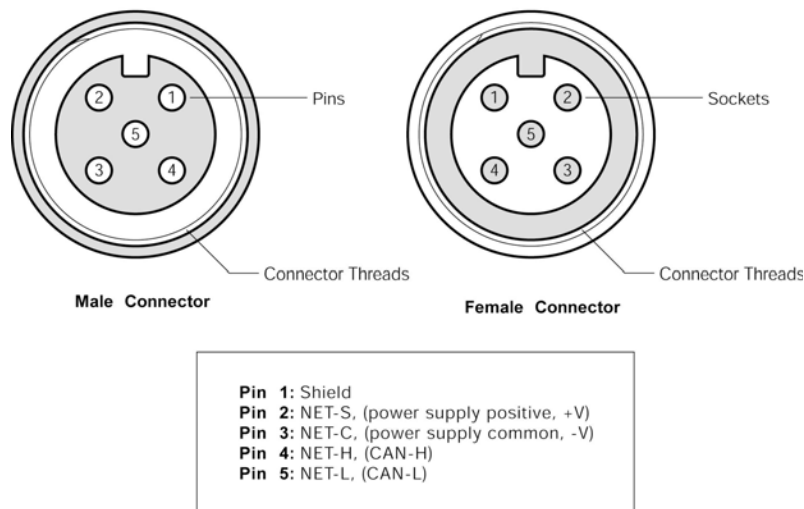

Figure 7 – NMEA 2000® Connector Face Views

2.4.2 LAN Connection

The IPG100 has one external RJ-45 LAN connector. The RJ-45 connector enables connection to an external network, which is necessary for N2KView® clients to be able to connect to the IPG100. The LAN connector can be made waterproof with the purchase of the optional PX837/5M00 Waterproof Ethernet Cable, which has a waterproof cover which engages the threads on the RJ-45 LAN connector, creating a waterproof seal.

2.4.3 USB N2KView® Hardware License Key Connection

The USB port on the IPG100 is for plugging in the N2KView® Hardware License Key (purchased separately). Hardware license keys that can be used with the IPG100 can also be used with the Windows N2KServer® software product. The USB connection can be made waterproof with the purchase of the optional PX0852 USB waterproof cover, which completely covers the N2KView® Hardware License Key and engages the threads on the USB connector, creating a waterproof seal.

NOTE:

There are two types of Hardware License Keys. The "old" key has a plastic case and carries a "SafeNet Sentinel" logo on the label. The "new" key has a gray metal case and has the Maretron logo etched into the metal case.



"Old" Key:



"New" Key:

The "new" key is required to use with the IPG100. The "new" key will also work with the N2KServer[®] PC software (version 3.0.4 and later). If you have an "old" key from a version of N2KView[®] you previously purchased, please contact Maretron sales to upgrade it to a "new" key so that you can use it with the IPG100.

2.5 Indicators

The IPG100 has three green LED indicators on its top surface:

NMEA 2000: This light will be red for several seconds after powerup while the IPG100 is initializing itself. Once this process is complete, this light will be lit a steady green to indicate that the main processor is active. The light will blink on and off to indicate data being transferred over the NMEA 2000[®] connection. If this light is lit red after the initialization has completed, it indicates that a problem has been detected.

LAN: This light will be on steadily to indicate that there is an active link connection between the IPG100 and the attached device. The light will blink on and off to indicate data being transferred over the LAN connection. If the light is off, then there is no active link connection.

USB: This light will be on to indicate that the USB port is active.

3 Configuring the IPG100

The IPG100 has several configurable parameters, which are shown below including the default values. If you are not using the default values, then you will need to refer to the corresponding section for configuring the IPG100 appropriately. You may configure the IPG100 using a Maretron DSM250 display or Maretron N2KAnalyzer[®] software.

3.1 Advanced Configuration

3.1.1 Device Instance

Program this parameter to the desired instance number for this device. You can program this parameter to any value between 0 and 252. The default device instance is 0

3.1.2 Installation Description

This entry allows you to modify the NMEA 2000® installation description text strings. You can enter any information you like here, such as the date the unit was installed, or the location in which it was installed, for later reference. Tools such as Maretron N2KAnalyzer® allow you to view these values later. The default installation description is blank text.

3.1.3 Restore Factory Defaults

This option restores all settings on the IPG100 device to their factory default state.

3.2 Device Label

Program this parameter with a text string which identifies this device. Maretron display products will display this label text when you are selecting data to display. The default device label is blank.

3.3 N2KServer® Password

Program this parameter with a text password. Any connecting N2KView® clients must be programmed with the same password in the “Connections Settings -> N2KServer® Connection ->Password” field in the N2KView® software. The default password is blank.

3.4 Configuring DHCP

This parameter determines whether or not the IPG100 obtains its LAN connection settings from a DHCP server on the local area network. When set to “Yes” (the default value), the IPG100 will obtain all necessary connection settings (IP Address, Subnet Mask, Default Gateway, and Default DNS) from a DHCP server on the local area network. Most routers have the capability to act as a DHCP server. Consult the user documentation for your network’s router for details.

If there is no DHCP server on the local area network (or if the IPG100 is connected directly to a DSM800 or directly to an MBB100), set the “DHCP” parameter to “No” and manually configure the IP Address (section 3.5), Subnet Mask (section 3.6), Default Gateway (section 3.7), Default DNS (section 3.8).

3.5 Configuring IP Address

This parameter is the IP (Internet Protocol) address used by the IPG100. You will need to specify this address to N2KView® clients in order to allow them to connect to the IPG100. If the “DHCP” parameter is set to “Yes”, you do not need to configure this parameter. If the “DHCP” parameter is set to “No”, you will need to configure this parameter.

3.6 Configuring Subnet Mask

This is a mask used to divide an IP Address into subnets. Basically, it tells the computer how much of the IP Address defines the network, and how much may be used by computers on the network. For most networks, the first three parts of the IP address define the network (i.e., every computer on the network must have the same values), and the last part defines the

computer (i.e., every computer on the network must have a different value). Where the value 255 appears in the subnet mask, the values define the network and must be the same.

The most common value is 255.255.255.0.

If the "DHCP" parameter is set to "Yes", you do not need to configure this parameter. If the "DHCP" parameter is set to "No", you will need to configure this parameter.

3.7 Configuring Default Gateway

This is the IP address of the router. If the "DHCP" parameter is set to "Yes", you do not need to configure this parameter. If the "DHCP" parameter is set to "No", you will need to configure this parameter.

3.8 Configuring Default DNS

This is the IP address of a computer on the Internet that can identify and locate computer systems and resources on the internet. In most cases, this should not be required by the IPG100 and may be left blank. If the "DHCP" parameter is set to "No", you will need to configure this parameter.

4 Maintenance

Regular maintenance is not required; however, an occasional inspection will ensure continued proper operation of the Maretron IPG100. Perform the following tasks periodically:

- Clean the unit with a soft cloth. Do not use chemical cleaners as they may remove paint or markings or may corrode the IPG100 enclosure or seals. Do not use any cleaners containing acetone, as they will deteriorate the plastic enclosure.
- Ensure that the unit is mounted securely and cannot be moved relative to the mounting surface. If the unit is loose, tighten the mounting screws.
- Check the security of all cable connections and tighten if necessary.

5 Troubleshooting

If you notice unexpected operation of the Maretron IPG100, follow the troubleshooting procedures in this section to remedy simple problems.

Symptom	Troubleshooting Procedure
N2KView® Clients cannot successfully connect to the IPG100	<ol style="list-style-type: none"> 1. If you have programmed the IPG100 to use DHCP, ensure that there is an active DHCP server on your LAN. 2. Ensure that the NMEA 2000® connection is secure, and that the NMEA 2000® network is powered. 3. Ensure that you have entered the correct IP Address of the IPG100 into N2KView®. 4. Ensure that the LAN LED on the IPG100 is lit, indicating an active link connection to the LAN. If it is not lit, check the Ethernet connection and make sure that the router or device to which the IPG100 is connected is powered on. 5. Ensure that a N2KView® Hardware License Key is plugged into the USB port of the IPG100. 6. Ensure that the Password entered into N2KView® under the "Connections Settings -> N2KServer® Connection" window matches the password that has been programmed into the IPG100. 7. Ensure that you have not used all of the available licenses on the N2KView® Hardware License Key.
LAN indicator not lit	<ol style="list-style-type: none"> 1. Ensure that the network cable is connected both to the IPG100 and to a switch or router or another network device. 2. Ensure that the device on the other end of the network cable is powered.
USB indicator not lit	<ol style="list-style-type: none"> 1. Ensure that the N2KView® hardware license key is properly plugged into the USB connector
NMEA 2000® indicator not lit	<ol style="list-style-type: none"> 1. Ensure that power is supplied to the NMEA 2000® indicator via the NMEA 2000® cable, and that the NMEA 2000® connection is secure.

Figure 8 – Troubleshooting Guide

If these steps do not solve your problem, please contact Maretron Technical Support (refer to Section 7 for contact information).

6 Technical Specifications

Specifications

Parameter	Value	Comment
NMEA 2000 [®] Connector	DeviceNet Micro-C	Industry Standard Waterproof
NMEA 2000 [®] Isolation	Opto-Isolated	No Electrical Connection Across Bridge
USB Standard	USB 1.1	
USB Connector	USB Type A	Industry Standard Waterproof, for Connection of N2KView [®] Hardware License Key Only
USB Supported Signals	D+, D-, +5V, GND	Bi-directional Gateway
USB Auxiliary Power	+5 Volts < 200 mA	
USB Baud Rate	Up to 12 Mb/s	Full Speed USB Data Rate
Ethernet Interface	100 Mb/s	
Ethernet Connector	RJ-45	Industry Standard Waterproof

Certifications

Parameter	Comment
NMEA 2000 [®] Standard	Level A
Maritime Navigation and Radiocommunication Equipment & Systems	IEC 61162-3
Maritime Navigation and Radiocommunication Equipment & Systems	IEC 60945
FCC and CE Mark	Electromagnetic Compatibility

NMEA 2000[®] Parameter Group Numbers (PGNs)

Description	PGN #	PGN Name	Default Rate
Response to Requested PGNs	126464	PGN List (Transmit and Receive)	N/A
	126996	Product Information	N/A
	126998	Configuration Information	N/A
Protocol PGNs	059392	ISO Acknowledge	N/A
	059904	ISO Request	N/A
	060416	ISO Transport Protocol, Connection Management	N/A
	060160	ISO Transport Protocol, Data Transfer	N/A
	060928	ISO Address Claim	N/A
	065240	ISO Address Command	N/A
	126208	NMEA Request/Command/Acknowledge	N/A

Electrical

Parameter	Value	Comment
Operating Voltage	9 to 32 Volts	DC Voltage
Power Consumption	<150mA	Average Current Drain
Load Equivalence Number (LEN)	3	NMEA 2000 [®] Spec. (1LEN = 50 mA)
Reverse Battery Protection	Yes	Indefinitely
Load Dump Protection	Yes	Energy Rated per SAE J1113

Mechanical

Parameter	Value	Comment
Size	5.000" x 4.500" x 2.375" 127mm x 114mm x 60 mm)	Including Flanges for Mounting
Weight	12 oz. (340 g)	

Environmental

Parameter	Value
IEC 60945 Classification	Exposed
Degree of Protection	IP67
Operating Temperature	-25°C to 55°C
Storage Temperature	-40°C to 70°C
Relative Humidity	93%RH @40° per IEC60945-8.2
Vibration	2-13.2Hz @ ±1mm, 13.2-100Hz @ 7m/s ² per IEC 60945-8.7
Rain and Spray	12.5mm Nozzle @ 100liters/min from 3m for 30min per IEC 60945-8.8
Solar Radiation	Ultraviolet B, A, Visible, and Infrared per IEC 60945-8.10
Corrosion (Salt Mist)	4 times 7days @ 40°C, 95%RH after 2 hour Salt Spray Per IEC 60945-8.12
Electromagnetic Immunity	Conducted, Radiated, Supply, and ESD per IEC 60945-10
Safety Precautions	Dangerous Voltage, Electromagnetic Radio Frequency per IEC 60945-12

7 Technical Support

If you require technical support for Maretron products, you can reach us in any of the following ways:

Telephone: 1-866-550-9100
Fax: 1-602-861-1777
E-mail: support@maretron.com
World Wide Web: <http://www.maretron.com>
Mail: Maretron, LLP
Attn: Technical Support
9014 N. 23rd Ave Suite 10
Phoenix, AZ 85021 USA

8 Installation Template

Please check the dimensions before using the following diagram as a template for drilling the mounting holes because the printing process may have distorted the dimensions.

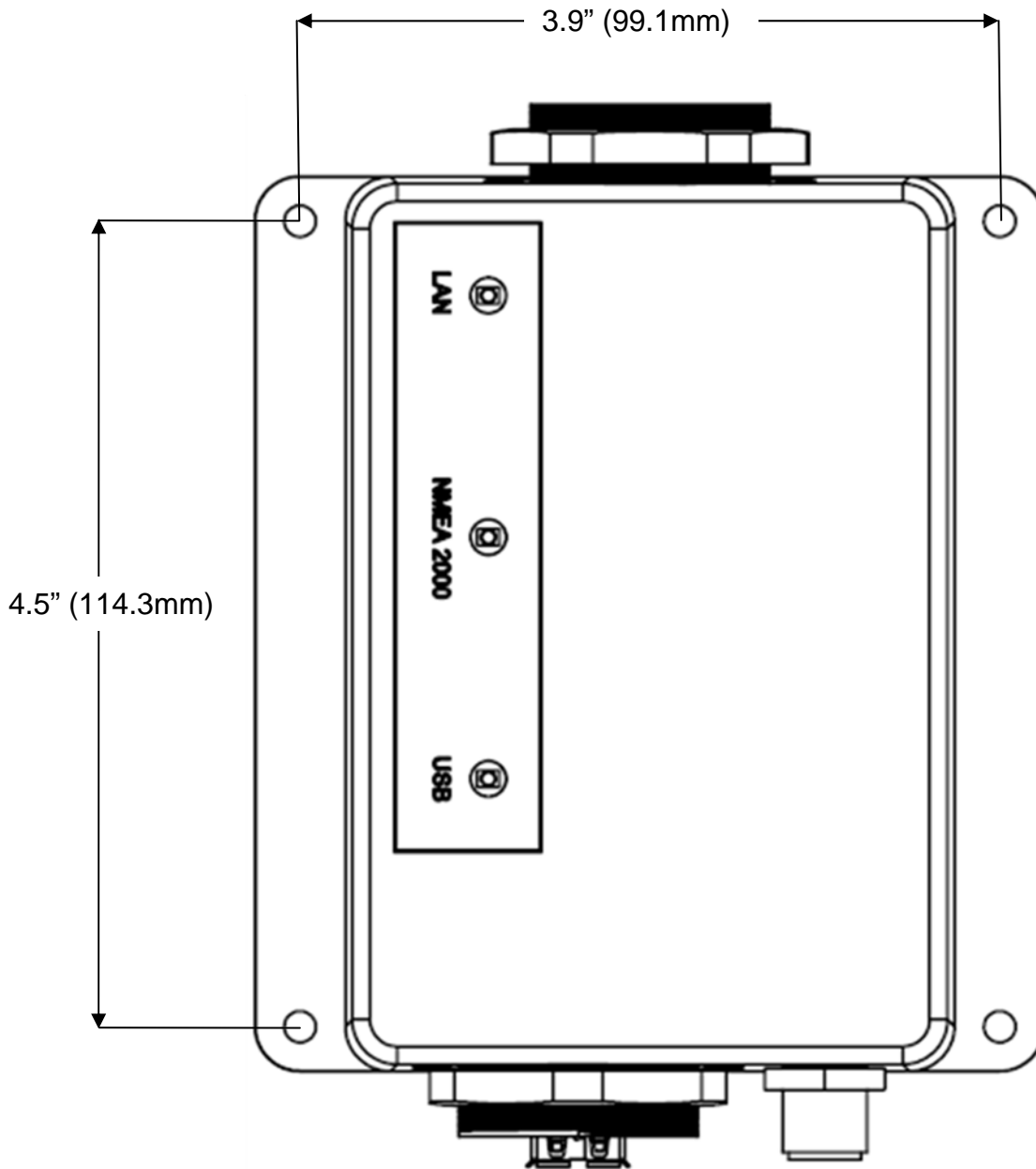

Figure 9 – Mounting Surface Template

9 Maretron (2 Year) Limited Warranty

Maretron warrants the IPG100 to be free from defects in materials and workmanship for **two (2) years** from the date of original purchase. If within the applicable period any such products shall be proved to Maretron's satisfaction to fail to meet the above limited warranty, such products shall be repaired or replaced at Maretron's option. Purchaser's exclusive remedy and Maretron's sole obligation hereunder, provided product is returned pursuant to the return requirements below, shall be limited to the repair or replacement, at Maretron's option, of any product not meeting the above limited warranty and which is returned to Maretron; or if Maretron is unable to deliver a replacement that is free from defects in materials or workmanship, Purchaser's payment for such product will be refunded. Maretron assumes no liability whatsoever for expenses of removing any defective product or part or for installing the repaired product or part or a replacement therefore or for any loss or damage to equipment in connection with which Maretron's products or parts shall be used. With respect to products not manufactured by Maretron, Maretron's warranty obligation shall in all respects conform to and be limited to the warranty actually extended to Maretron by its supplier. The foregoing warranties shall not apply with respect to products subjected to negligence, misuse, misapplication, accident, damages by circumstances beyond Maretron's control, to improper installation, operation, maintenance, or storage, or to other than normal use or service.

THE FOREGOING WARRANTIES ARE EXPRESSLY IN LIEU OF AND EXCLUDES ALL OTHER EXPRESS OR IMPLIED WARRANTIES, INCLUDING BUT NOT LIMITED TO THE IMPLIED WARRANTIES OF MERCHANTABILITY AND OF FITNESS FOR A PARTICULAR PURPOSE.

Statements made by any person, including representatives of Maretron, which are inconsistent or in conflict with the terms of this Limited Warranty, shall not be binding upon Maretron unless reduced to writing and approved by an officer of Maretron.

IN NO CASE WILL MARETRON BE LIABLE FOR INCIDENTAL OR CONSEQUENTIAL DAMAGES, DAMAGES FOR LOSS OF USE, LOSS OF ANTICIPATED PROFITS OR SAVINGS, OR ANY OTHER LOSS INCURRED BECAUSE OF INTERRUPTION OF SERVICE. IN NO EVENT SHALL MARETRON'S AGGREGATE LIABILITY EXCEED THE PURCHASE PRICE OF THE PRODUCT(S) INVOLVED. MARETRON SHALL NOT BE SUBJECT TO ANY OTHER OBLIGATIONS OR LIABILITIES, WHETHER ARISING OUT OF BREACH OF CONTRACT OR WARRANTY, TORT (INCLUDING NEGLIGENCE), OR OTHER THEORIES OF LAW WITH RESPECT TO PRODUCTS SOLD OR SERVICES RENDERED BY MARETRON, OR ANY UNDERTAKINGS, ACTS OR OMISSIONS RELATING THERETO.

Maretron does not warrant that the functions contained in any software programs or products will meet purchaser's requirements or that the operation of the software programs or products will be uninterrupted or error free. Purchaser assumes responsibility for the selection of the software programs or products to achieve the intended results, and for the installation, use and results obtained from said programs or products. No specifications, samples, descriptions, or illustrations provided Maretron to Purchaser, whether directly, in trade literature, brochures or other documentation shall be construed as warranties of any kind, and any failure to conform with such specifications, samples, descriptions, or illustrations shall not constitute any breach of Maretron's limited warranty.

Warranty Return Procedure:

To apply for warranty claims, contact Maretron or one of its dealers to describe the problem and determine the appropriate course of action. If a return is necessary, place the product in its original packaging together with proof of purchase and send to an Authorized Maretron Service Location. You are responsible for all shipping and insurance charges. Maretron will return the replaced or repaired product with all shipping and handling prepaid except for requests requiring expedited shipping (i.e. overnight shipments). Failure to follow this warranty return procedure could result in the product's warranty becoming null and void.

Maretron reserves the right to modify or replace, at its sole discretion, without prior notification, the warranty listed above. To obtain a copy of the then current warranty policy, please go to the following web page:

<http://www.maretron.com/company/warranty.php>